



---

**3.5" Form Factor  
Mirror Drive**

**Serial ATA MODEL**

**SVRE-U Series**

**User's Manual**

P/N A204182

Revision 1.2

---

This page is intentionally left blank.

# Introduction

---

Thank you for selecting the **3.5" Form Factor SATA Mirror Drive Model**. This manual describes the proper installation procedures, operation and maintenance of your **SATA Mirror Drive**, and will help you familiarize with its features.

## NOTICE

Please be sure to read first the user's manual before using your **SATA Mirror Drive**. This manual provides information on the appropriate handling procedures and configurations for all product functions. This information will allow the user to take full advantage of the **3.5" Form Factor SATA Mirror Drive Model**.

In the unlikely event that you experience problems, this manual provides helpful information and instructions.

## RETAINING PACKAGING

The original packaging materials protect the **SATA Mirror Drive** from damage during shipment. After unpacking the **SATA Mirror Drive**, please retain the packaging materials in case you need to ship the **SATA Mirror Drive** in the future. This product is sealed in an antistatic and moisture-proof bag before shipping. Open the bag only when you are about to begin setting it up.

## RECORDING THE PRODUCT NAME, VERSION, AND SERIAL NUMBERS

Before installing the **SATA Mirror Drive** on the host computer, please jot down the model name, version, and serial numbers in the spaces provided for at the last page of this user's manual. Kindly keep these for your record purposes.

Section " [2.1 Part Names](#) " shows the label location of model name, version, and serial number.

- **THIS DOCUMENT MAY NOT BE REPRODUCED OR COPIED IN WHOLE OR IN PART.**
- **THE CONTENTS OF THIS DOCUMENT ARE SUBJECT TO CHANGE WITHOUT NOTICE.**
- **WE HAVE MADE EVERY EFFORT TO ENSURE THE ACCURACY AND COMPLETENESS OF THIS DOCUMENT. IF YOU FIND INACCURACIES OR OMISSIONS, PLEASE CONTACT YOUR DISTRIBUTOR.**

**Copyright© Storage Vision Co., Ltd. 2011 - 2021All rights reserved.**

(To get the latest copy of this specification and to know more information about STR-V and its products, please visit <http://www.str-v.com> )



## To ensure the safe use of this product:

---

This user's manual uses the following symbols to highlight the important points related to the safe use of this product. Please observe all safety information as indicated.

### SAFETY SYMBOLS

To protect against personal injury and product damage, the following symbols are used throughout this manual to highlight safety information.

	<b>Warning</b>	Indicates a potentially hazardous situation that may result in death or serious injury to the user or severe damage to the product.
	<b>Caution</b>	Indicates a potentially hazardous situation that may result in serious injury to the user or damage to the product.
	<b>Important</b>	Indicates important information wherein failure to observe may result to improper product function.

### WARNING / CAUTION LABELS

Labels with black lettering against a yellow background affixed either to the exterior or interior of the product are **Warning** or **Caution** labels that provide important safety information. Observe all the directions given on these labels.

In cases where **Warning** or **Caution** labels can be found aside from those written in the manual, be sure to follow the directions as mentioned.

## **Warning**

---

- If you detect any abnormal conditions, such as smoke or foul odors, shut off immediately the power of the host computer.
- If any foreign substance or material (metals, water, liquids, etc.) seeps into the **SATA Mirror Drive**, shut off immediately the power of the host computer.
- Do not use the **SATA Mirror Drive** in hot or damp locations. Using this product in such locations may result in fire, electrical shock, or damage.
- Do not disassemble or modify this product. STR-V cannot guarantee the performance or safety of any product that has been repaired by the customer or by an unauthorized third party. Repairing by your self may result in fire, electrical shock, or damage of the product.
- Before connecting or disconnecting the interface connector, turn off first the power of the host computer and any other connected devices. To avoid placing excessive stress on the printed circuit board of the **SATA Mirror Drive**, push or pull the connector only along the axis perpendicular to the board. Avoid bending the connectors. Also avoid using undue force to connect or disconnect the connectors or cables, which may result in fire, electrical shock, or damage.

## Caution

---

- Do not use the **SATA Mirror Drive** in locations subject to vibration or shock exceeding the specified values. Usage in such locations may result in malfunctions or disk failure.
- Do not use the **SATA Mirror Drive** in locations or conditions susceptible to condensation. Rapid temperature change may cause condensation to form in the **SATA Mirror Drive**. If you think condensation has occurred, allow the **SATA Mirror Drive** to acclimate to the new environment. When there is a rapid temperature change, avoid using the **SATA Mirror Drive** until it reaches the new ambient temperature.
- Do not place the **SATA Mirror Drive** near electronic components with strong electromagnetic fields, such as televisions or loudspeakers. Usage of the **SATA Mirror Drive** in such locations may result in malfunctions or disk failure.
- Turn off the power before moving the unit enclosing the **SATA Mirror Drive**. This will prevent damage to the HDD and other internal components of the **SATA Mirror Drive**.
- Do not turn on the power immediately after turning it off, or turn off the power immediately after turning it on. Leave at least 20 seconds in-between successive operations involving power on or off. This will help prevent damage or malfunction to the mounted HDD. The HDD motor spindle requires about 20 seconds to stop rotating and come to a full rest. In addition, when removing the correctly functioning drive unit for replacement, turn off the power and wait for at least 20 seconds.
- Do not remove a fully functional drive unit while the power is still on. The **SATA Mirror Drive** controller unit will consider the drive unit as failed if it is removed. Removing a fully functional drive unit may also damage the disk heads and platter inside the HDD.
- Store the **SATA Mirror Drive** in the antistatic bag. Leaving this product unpacked and unused for a long period of time may lead to malfunction or disk failure.
- Avoid applying excessive pressure to the covers of the drive unit, which may lead to malfunction or disk failure.
- After unpacking from transport, ensure first that each disk drive is properly inserted before turning on the power.

## Important

---

- Back up all important data stored in the **SATA Mirror Drive** to a suitable storage medium, such as tape drive or MO drive. This product's mirroring technology prevents data loss even if one drive unit fails. However, if two drive units fail at the same time or if a non-redundant part fails, data loss may still occur. Additionally, accidental deletion of data or equipment damage may also result in data loss.
- Do not block the ventilation openings of the HDD. Lack of cooling airflow may lead to hard disk drive failure.
- Wait at least 10 seconds after the access indicator has stopped flashing before initiating the shutdown procedure for your host computer. The **SATA Mirror Drive** uses cache memory to store the data frequently accessed from the HDD. Except in emergencies, you must follow the operating system's shutdown procedures. Failure to do so may result in loss of data stored in cache memory.
- Never remove or exchange the drive units, except to replace failed controller units or drive units, since the **SATA Mirror Drive** controls the drive units by using its serial numbers. Thus, removal or replacement may result in failure to boot up the host computer.
- When installing it in the host computer's bay, mount the **SATA Mirror Drive** securely using the mounting screws provided (0.49 Nm is recommended).

## Handling Static-Sensitive Device

---

To prevent damage to components due to static electricity, observe the following precautions when handling this product.

- Before handling the **SATA Mirror Drive** or other static-sensitive devices, touch a metal object, such as the metal enclosure of the host computer, to discharge any static electricity from your body.
- Always handle components carefully. Never touch exposed circuitry.
- When replacing controller units or drive units, or when moving the **SATA Mirror Drive**, place the antistatic bag used in wrapping the product during shipment on a flat, level surface. Use this as your **SATA Mirror Drive** working area.



## SATA Mirror Drive Installation Important Points

---

When installing the **SATA Mirror Drive** in the host computer, ensure that the drive unit is installed horizontally, as in <A> below.

Do not install the unit vertically, i.e. with the connector facing either up or down, as in <B>.

Furthermore, when installing the unit on its side as in <C>, consult first with your distributor.

<A> Drive unit in horizontal position

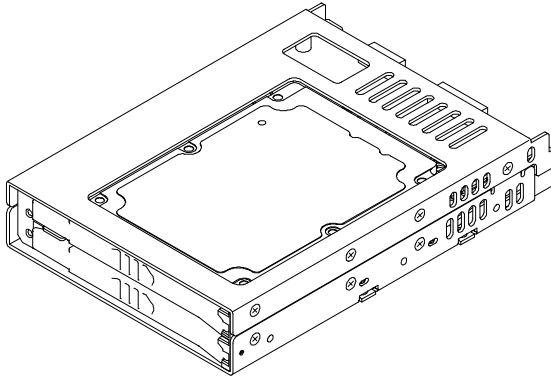

<B> Drive unit in vertical position

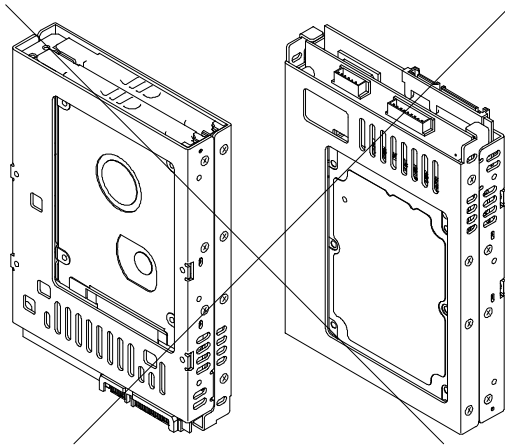

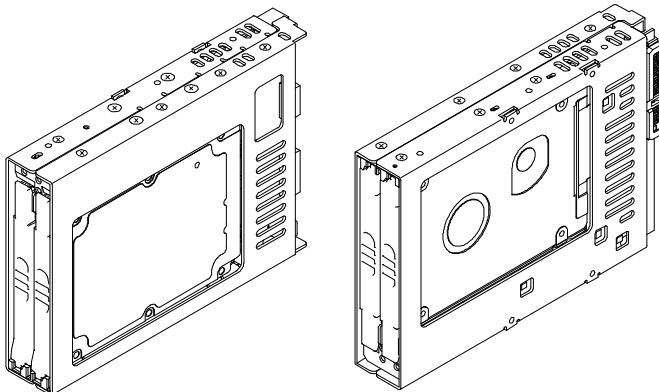

<C> Drive unit on its side



# Contents

---

Introduction .....	i
To ensure the safe use of this product:.....	ii
 Warning .....	iii
 Caution .....	iv
 Important .....	v
Handling Static-Sensitive Device .....	vi
SATA Mirror Drive Installation Important Points .....	vii
Contents .....	viii
1. 3.5" Form Factor SATA Mirror Drive Functions .....	1
1.1 Features .....	1
1.2 Mirroring .....	1
1.3 Cache Buffer Function.....	1
1.4 Data Rebuilding .....	2
1.5 Revival Reconstruction .....	2
2. Outline .....	3
2.1 Part Names .....	3
2.2 Dimensions.....	4
2.2.1 SATA Mirror Drive.....	4
2.2.2 5-inch Bay Mirror Drive Installation Attachment .....	5
3. Installation .....	6
3.1 DIP Switch Settings .....	6
3.2 Mounting in the Host Computer.....	6
3.3 Cable Connection.....	7
3.4 Turning on The Main Power .....	7
4. Settings .....	8
4.1 DIP Switch.....	8
4.1.1 Operating Mode (Do not change) .....	9
4.1.2 Write Cache Mode.....	9
4.1.3 Revival Reconstruction .....	9
4.1.4 Buzzer .....	9
5. Status Display.....	10
5.1 Indicator.....	10
5.1.1 Access Indicator .....	10
5.1.2 Drive Status Indicator .....	10
5.1.3 Buzzer .....	11
5.2 External Output Signal .....	12
5.2.1 Status Signal .....	12
5.2.2 External LED Connector.....	14
5.2.3 Buzzer Stop Connector .....	15
6. Trouble shooting .....	16
6.1 Trouble indication .....	16
6.2 Replacing Drive Unit.....	17
6.2.1 Replacement of 1 Drive Unit .....	17
6.2.2 Replacement of Both Drive Units .....	18
6.3 Controller Unit Replacement.....	19
6.3.1 When both drive units are functioning normally.....	20
6.3.2 When one drive unit has failed: .....	20
6.4 Other problems .....	21

<b>Appendix-A Specifications .....</b>	<b>22</b>
<b>Appendix-B Accessories .....</b>	<b>23</b>
<b>Appendix-C Factory Default Setting .....</b>	<b>24</b>
<b>Appendix-D Replacement Parts .....</b>	<b>25</b>
<b>Information.....</b>	<b>26</b>

# 1. 3.5" Form Factor SATA Mirror Drive Functions

Incorporating two SATA 2.5-inch Hard Disk Drives, the STR-V **3.5" Form Factor SATA Mirror Drive** uses mirroring technology to safeguard data and to provide uninterrupted operations.

Since the host computer will recognize the **SATA Mirror Drive** as a standard SATA HDD, installing the **SATA Mirror Drive** simply involves connecting it to a SATA cable from the host computer.

## 1.1 Features

- Supports Mirroring technology (RAID Level 1) implemented via hardware thereby reducing system overhead.
- In the event that one of the drive unit fails, the **SATA Mirror Drive** will continue to function, maintaining data integrity.
  - When the failed disk is replaced with a new replacement disk, data rebuilding will begin automatically.
  - Hot plug function is supported at drive interface thereby improving system reliability.
- Based on the industry standard Serial ATA interface, the **SATA Mirror Drive** can be used like any other standard Serial AT HDD.
  - No special device drivers needed.
  - Compatible with most operating systems
- Serial ATA Interface conforming to ATA/ATAPI-7 Specifications
  - SATA- I with a maximum data transfer speed of 3Gbps at the host interface
  - Uses two 2.5-inch SATA drives that supports a maximum data transfer speed of 3Gbps
- Cache function feature for improved system performance.

## 1.2 Mirroring

Mirroring technology involves writing of data to two drive units simultaneously. If one drive unit fails, data is written to and read from the other drive unit.

## 1.3 Cache Buffer Function

The **SATA Mirror Drive** is equipped with a large cache memory capacity. With write cache mode enabled, the **SATA Mirror Drive** will signal completion of command processing to the host computer when data is written to cache memory. The performance will be improved by writing accumulated data to the HDD when the host computer is not accessing the **SATA Mirror Drive**. Write cache mode is enabled thru a DIP Switch. The default setting at shipment is "enabled".

	<h3>Important</h3>	<p>Always observe the shutdown procedure specified for the host computer's operating system. In delicate situations, try to wait at least 10 seconds to be sure that both the access indicator and the drive status indicator have stopped flashing before shutting off the power. Turning off the power while the access indicator or the drive status indicator is still on may result in loss of data currently located in cache memory.</p>
---	--------------------	---

## 1.4 Data Rebuilding

If a failed drive unit is correctly replaced, data rebuilding (the copying of all data from the fully functional drive unit to the new replacement drive unit) will start automatically.

During data rebuilding, the drive status indicator of the fully functional drive unit will light green. The drive status indicator of the replacement drive unit will blink orange every one second.

	<b>Caution</b>	Do not turn off the host computer while the <b>SATA Mirror Drive</b> is still rebuilding the data to prevent loss of data or failure.
---	----------------	---

When a sector of the fully functional drive unit can not be read during data reconstruction, the **SATA Mirror Drive** skips copying the bad sector and continues to reconstruct the remaining data. These skipped sectors will no longer be readable. Once some data is written to this sector, it can be read correctly again.

	<b>Important</b>	If the data recovery process skips some sectors during data rebuilding, then the data on these sectors will be lost. Periodic backup is recommended.
---	------------------	--

## 1.5 Revival Reconstruction

When an error occurs in a drive unit and the mirror controller cannot get the response from the drive for 30 seconds, the controller will issue the reset command to the drive and check its status again.

If the drive recovers, the **SATA Mirror Drive** returns to the normal operation. But if not, the controller treats the drive as a failed drive.

The function "Revival Reconstruction" turns the power of the drive OFF/ON. And if the drive status becomes ready, reconstruction is started.

Revival reconstruction is executed up to two times. After the same error occurs three times, the **SATA Mirror Drive** will remain in Degraded Mode. Then the failed drive status indicator (LED) will light orange. The function can be enabled /disabled by Dip Switch. Factory default is "enabled".

The **SATA Mirror Drive** still responds to the host normally even during reconstruction. After the reconstruction is finished, the **SATA Mirror Drive** returns to normal mode automatically.

## 2. Outline

### 2.1 Part Names

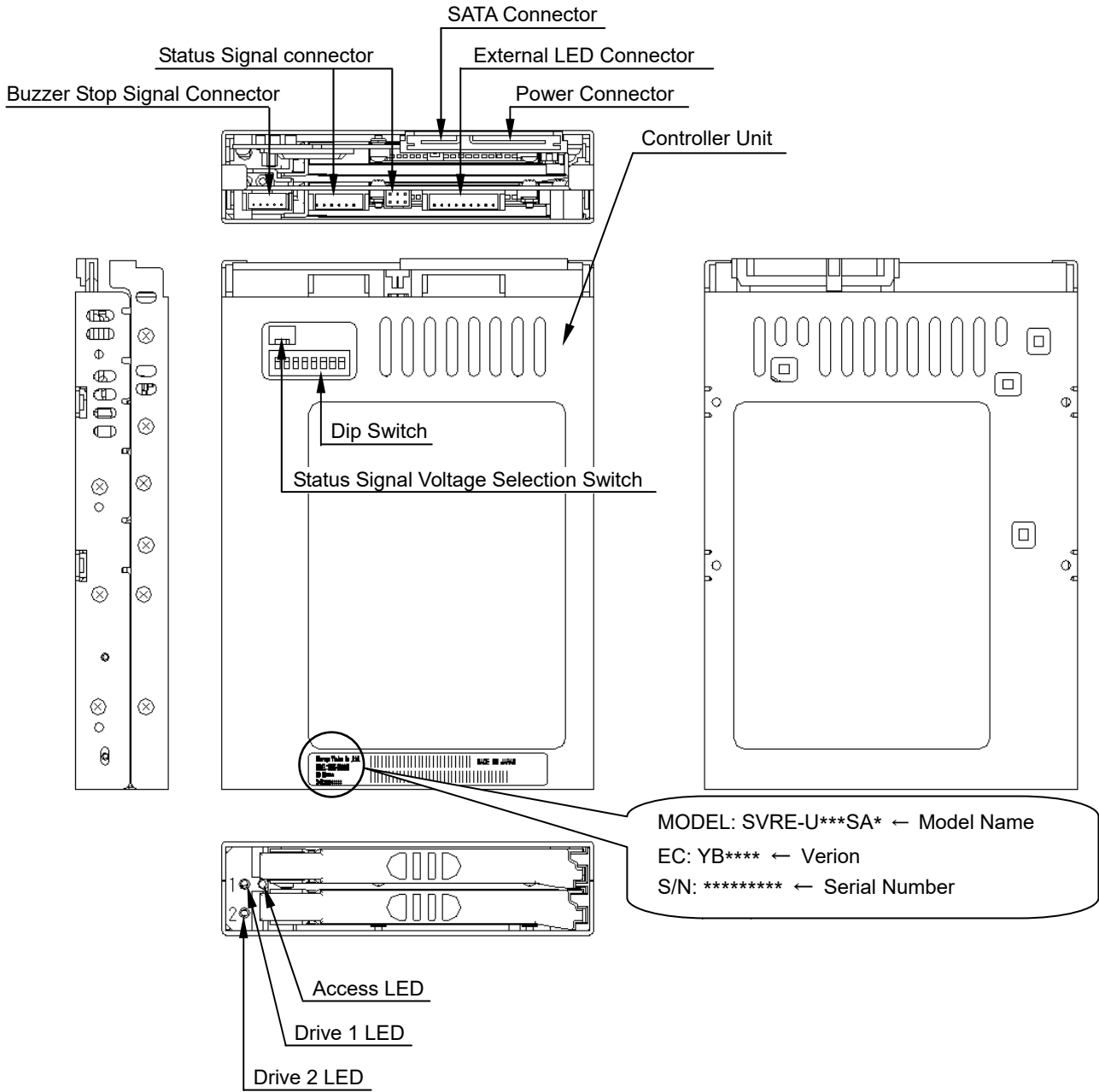

## 2.2 Dimensions

### 2.2.1 SATA Mirror Drive

Unit : mm

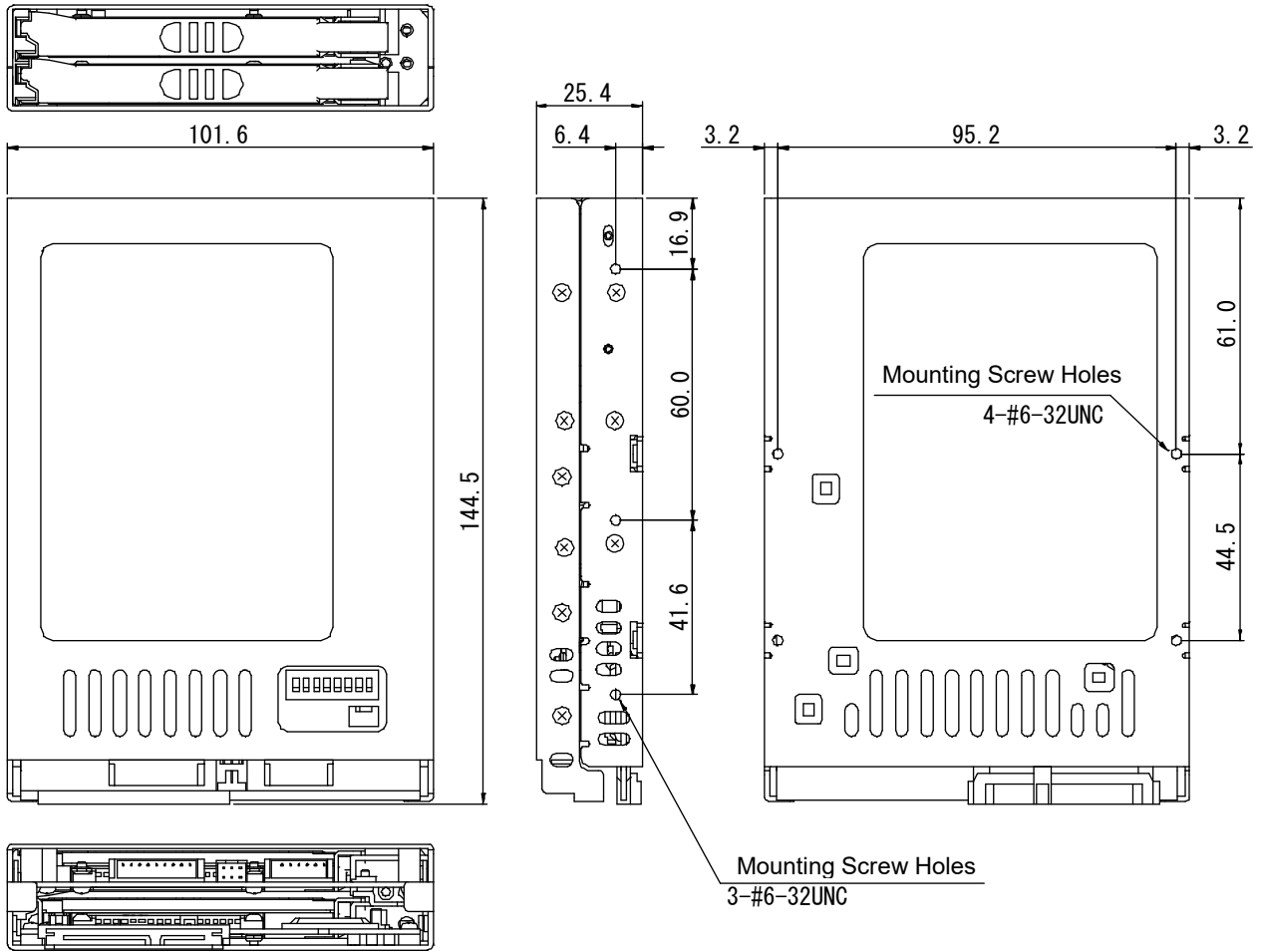

## 2.2.2 5-inch Bay Mirror Drive Installation Attachment

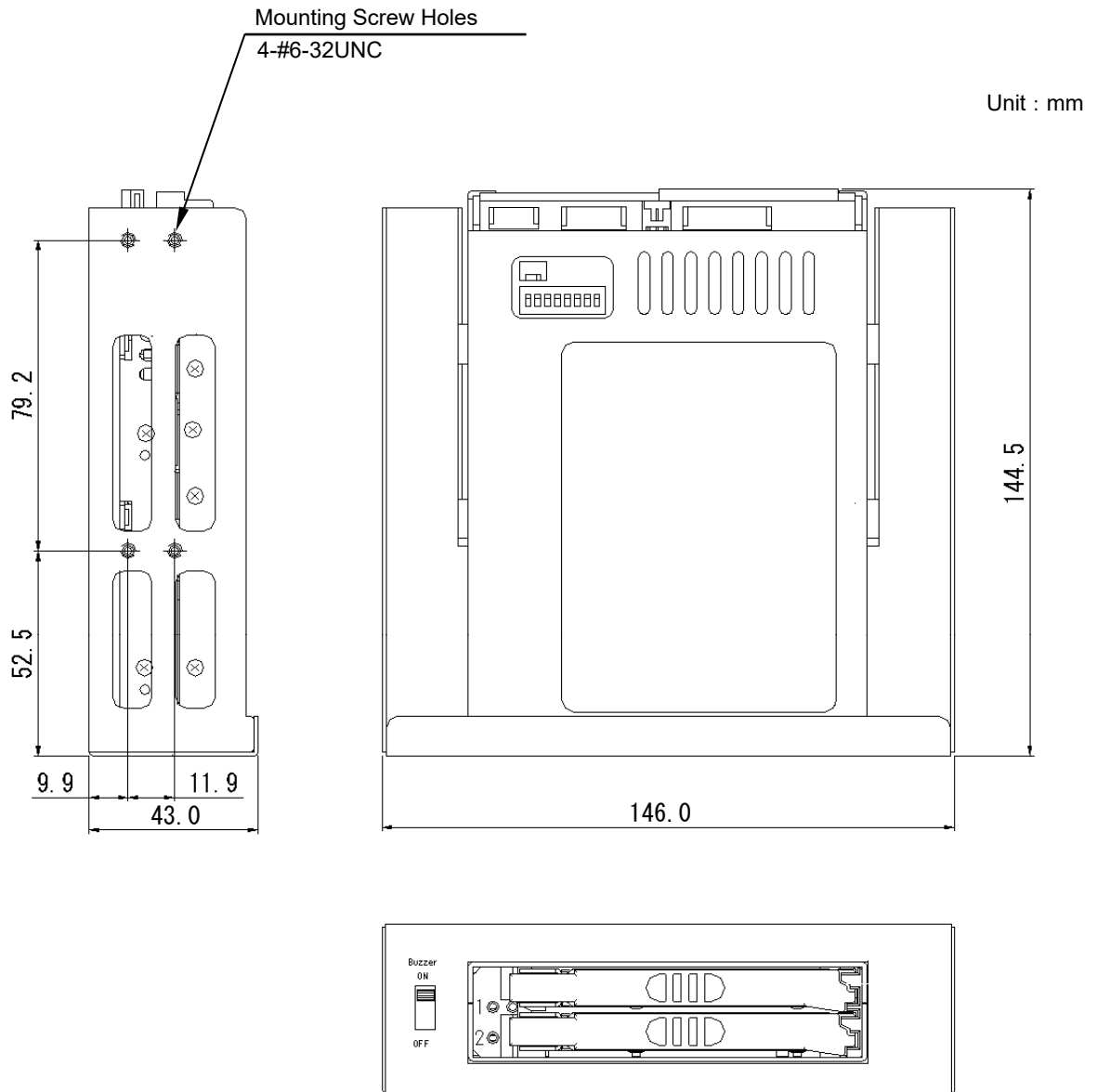



## 3. Installation

### 3.1 DIP Switch Settings

Before mounting the **SATA Mirror Drive** in your host computer, double-check the DIP Switch settings. Refer to "4. Settings" for the configurations of the DIP switch. For default settings, refer to "[Appendix-C Factory Default Settings](#)."

	<b>Caution</b>	When setting the switches and attaching the cables, ensure first that the power supply of the host computer is turned off.
---	----------------	--

### 3.2 Mounting in the Host Computer

When mounting in the host computer, use the attached mounting screws and the specified mounting holes. The mounting screw hole locations are shown in "[2.2 Dimensions](#)." An example of a mounting screw hole location is shown below.

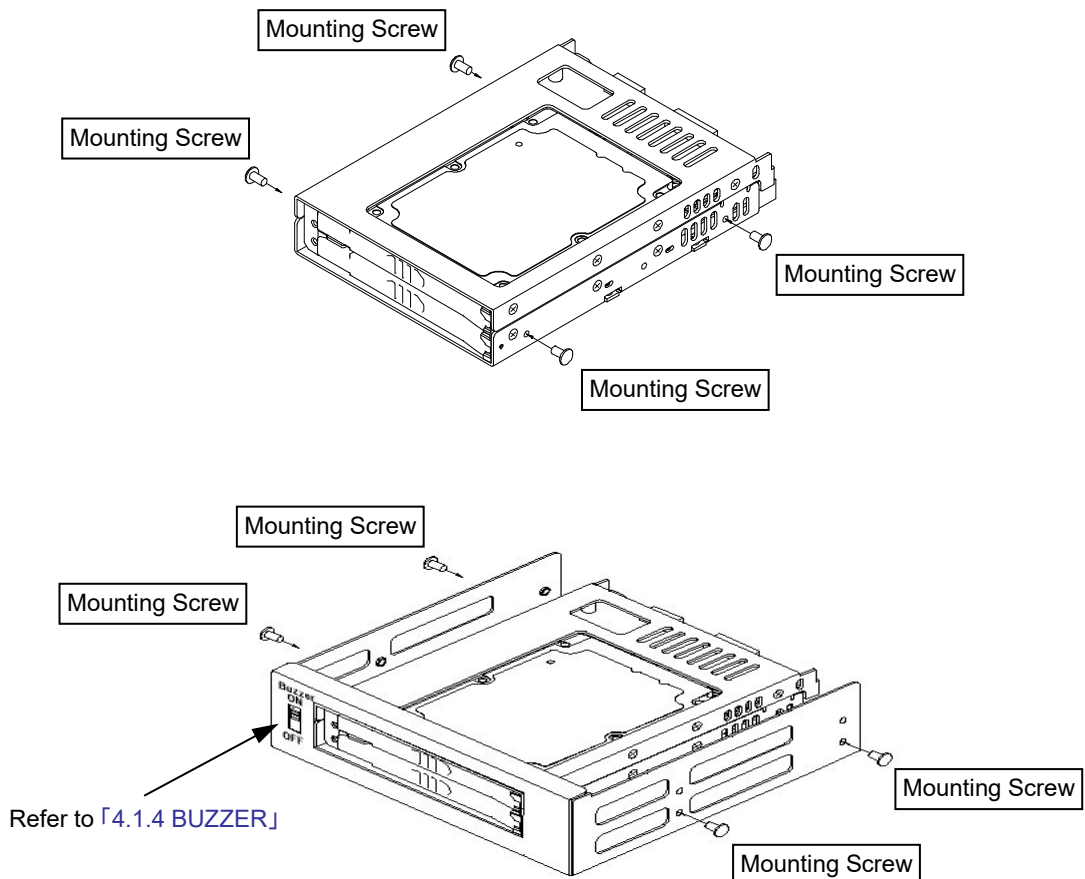

	<b>Caution</b>	When installing into the host computer, provide sufficient cooling in order to ensure that the surface temperature of the drive unit remains below 60°C.
---	----------------	--

### 3.3 Cable Connection

- <1> Connect SATA power cable that supplies DC +5V.
- <2> Use a standard SATA signal cable to connect to the host computer.

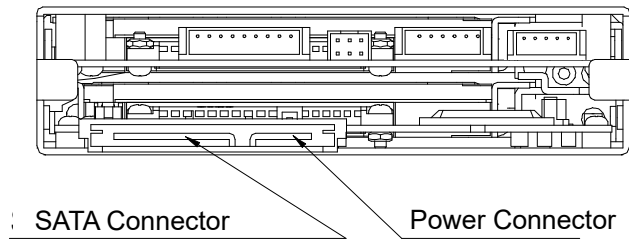

### 3.4 Turning on The Main Power

Before turning on the host computer, gently press the front face of each drive unit to confirm that these are firmly inserted and verify if the lever lock is firmly fixed. Next, turn on the host computer's main power supply and check if the host computer detects the unit correctly.

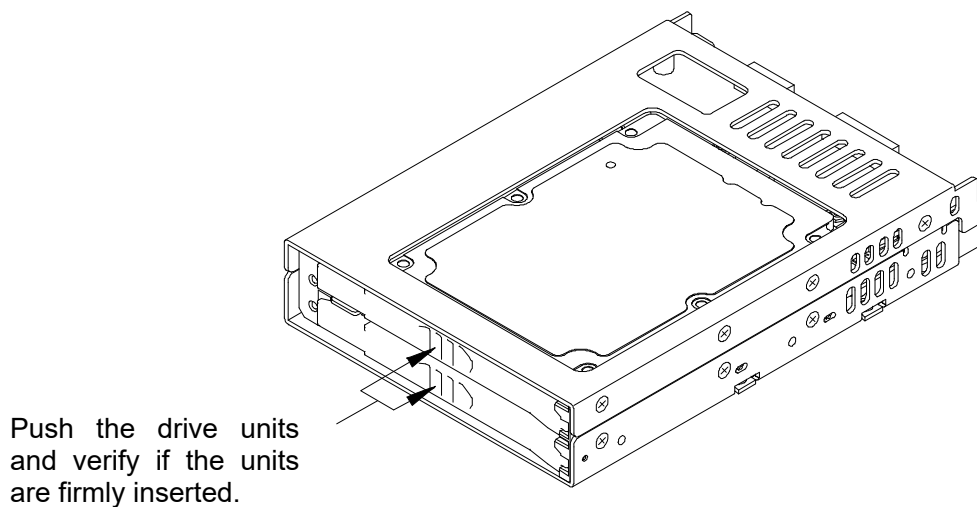

	<b>Caution</b>	Before turning on the host computer, make sure that both the Signal and power cables are attached properly.
---	----------------	---

## 4. Settings

### 4.1 DIP Switch

The DIP Switch can be used to change the settings of Write Cache mode, DMA setting Revival Reconstruction Feature and Buzzer Enable/Disable Features of the **SATA Mirror Drive**.

It is located on the upper right side of the sub-card (at the back of CN13).

Since the **SATA Mirror Drive** is a high-speed and reliable storage unit, its default DIP Switch settings are set to maximize its performance.

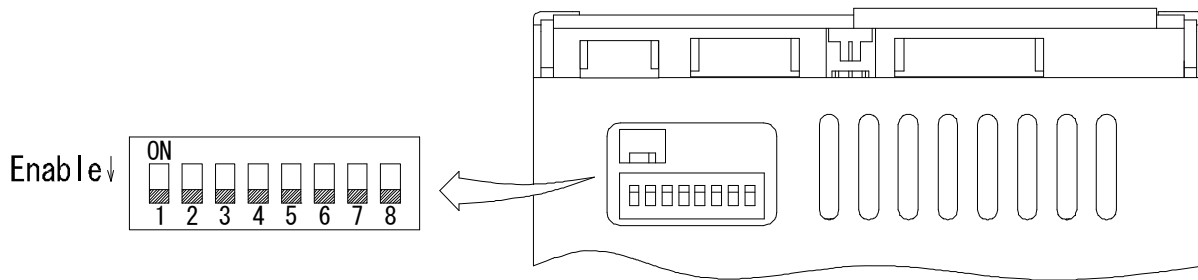

DIP Switch	Functions	Default Switch position
S1	Normal Mode Bit 1,2,3 (Refer to 「4.1.1 Operating Mode」 )	OFF (Normal)
S2		
S3		
S4	Reserved	OFF
S5	Write Cache (Refer to 「4.1.2 Write Cache Mode」 )	OFF (Enabled)
S6	Revival Reconstruction (Refer to 「4.1.3 Revival Reconstruction」 )	OFF (Enabled)
S7	Buzzer (Refer to 「4.1.4 BUZZER」 )	OFF (Enabled)
S8	Reserved	OFF

	<h3>Caution</h3>	<p>Except for S6 &amp; S7, turn off the power of the host computer before changing the setting of the switches. (The above diagram shows the default factory settings before shipping.)</p>
		<p>Do not change the Mode Bit switches (S1, S2, S3, S4) and S8. Otherwise, performance and function variations may occur in the unit.</p>

#### 4.1.1 Operating Mode (Do not change)

The operating mode switches (S1, S2, S3, S4 & S8) are set to normal mode (mirror mode). Do not change this setting.

	<b>Important</b>	Changing the operation mode switches will result in loss of data.
---	------------------	---

#### 4.1.2 Write Cache Mode

This bit sets the write cache mode. If set to "OFF" (Default Setting meaning Write Cache Enabled), the **SATA Mirror Drive** will signal completion of command processing to the host computer when the data has been written to cache memory. If set to "ON", the **SATA Mirror Drive** will signal completion of command processing to the host computer when data is actually written to the drive unit.

	<b>Important</b>	Always observe the shutdown procedure specified for the host computer's operating system. In delicate situations, try to wait at least 10 seconds to be sure that both the access indicator and the drive status indicator have stopped flashing before shutting off the power. Turning off the power while the access indicator or the drive status indicator remains lit may result in loss of data currently located in cache memory.
--	------------------	--

#### 4.1.3 Revival Reconstruction

If the bit is set to "OFF" (Default Setting meaning Revival Reconstruction Enabled), the **SATA Mirror Drive** will attempt to do data reconstruction after Error Recovery Procedure fails while in Retry Mode. The **SATA Mirror Drive** will not remain in Degraded Mode but instead, will automatically do data reconstruction to trying to revive the drive up to two times.

#### 4.1.4 Buzzer

If the bit is set to "OFF" (Default Setting meaning Buzzer Enabled), the buzzer will sound when any error is detected. In the event of a drive unit failure, the buzzer will continue to sound until the failed drive unit is replaced. The buzzer can be stopped if the switch position is changed to "ON".

Set back the buzzer to "OFF" after the failed drive unit has been replaced.

When an external bracket is used for the 5" Drive Bay installation, please make sure that Bit 7 setting of the Dip Switch is set to Enable. The buzzer sound can be turned ON and OFF through the Buzzer switch in the external bracket. If the buzzer is turned OFF prior to drive replacement, slide it back to ON after the new drive unit has been inserted.

## 5. Status Display

### 5.1 Indicator

LED indicators on the front display the status of both controller unit and drive units.

#### 5.1.1 Access Indicator

ACCESS	Green	<1> When the power is turned on. <sup>(*)</sup> <2> Processing a command from the host computer. Either of the above.
	Orange	Controller unit failure.
	Orange Flashing	<1> Both drive units have failed, both drive units are not correctly inserted. (Both drive status indicators are off.) <2> When one drive unit has failed and the fully functional drive unit has been erroneously replaced. (Both drive status indicators show green simultaneously.) <3> Both drive units have been replaced. (Both drive status indicators show green simultaneously.) Any of the above.

#### 5.1.2 Drive Status Indicator

Display	Description
Green	<1> When the power is turned on. <sup>(*)</sup> <2> Processing a command from the host computer. <3> Then <b>SATA Mirror Drive</b> is processing an internal command. Either of the above
Orange	<1> Drive unit failure
Orange Flashing	Target drive unit of data rebuilding. <sup>(*)</sup> (Source drive unit LED is green at the same time)

<sup>(\*)</sup> When the power is turned on, both the access indicator drive status indicators lights up green. When **SATA Mirror Drive** boot up process is complete, all will be turned off.

<sup>(\*)</sup> Drive Status Indicator will go out after data rebuilding.

	<b>Important</b>	If the drive status indicator flashes orange, immediately replace the said drive unit. Leaving the <b>SATA Mirror Drive</b> with a failed drive unit will result in data loss if the other drive unit fails.
---	------------------	--

### 5.1.3 Buzzer

If this is set to "ENABLE," in the event of a failure, the buzzer will beep at the interval specified below.

Drive unit 1 failed

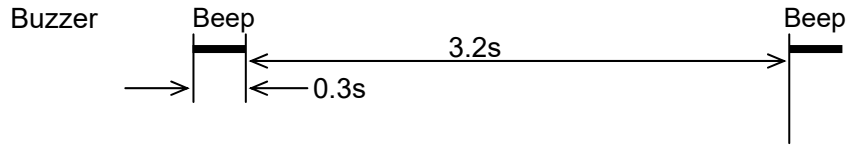

Drive unit 2 failed

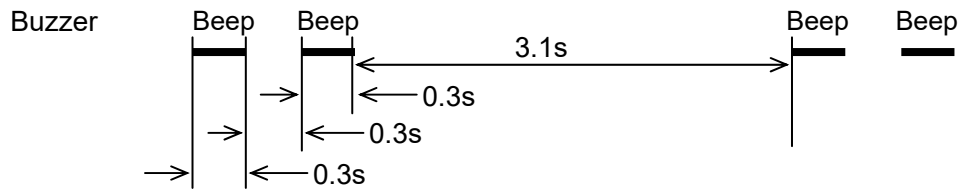

System stopped (Both drive units have failed)

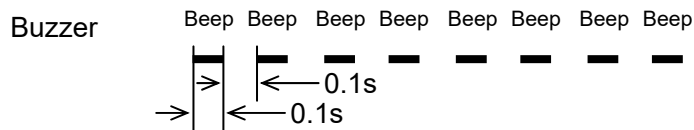

## 5.2 External Output Signal

It is possible to monitor the **SATA Mirror Drive** status externally. The locations of the connector are shown in the figure below.

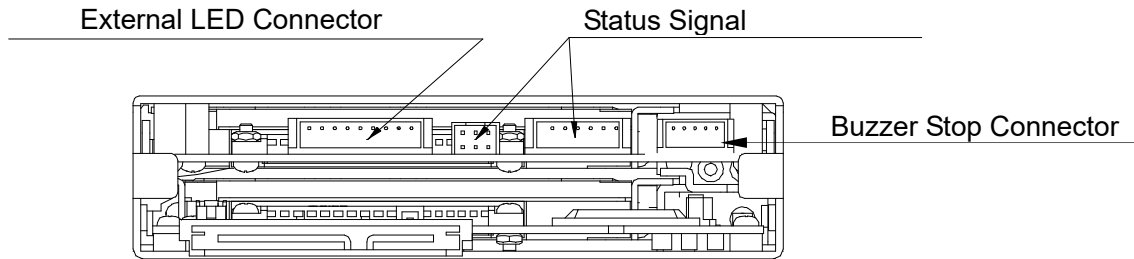

### 5.2.1 Status Signal

External status output is transmitted as a 3-bit signal through the Status Bit connector. This table shows the pin configurations, status definitions, internal circuitry, electrical specifications, and connector specifications for the status output signal.

- The connector signal pins are configured as follows:

	Signal	Connector Pin Assignment
1	GND	
2	+3.3V <sub>DC</sub> (Default) / +5V <sub>DC</sub> (Option)	
3	Status Bit 2	
4	Status Bit 1	
5	Status Bit 0	
6	GND	

- Status output is transmitted in 3-bit signals, as follows:

	Bit 2	Bit 1	Bit 0	Status
0	L	L	L	Normal Operation
1	L	L	H	Drive Unit 1 Failed
2	L	H	L	Drive Unit 2 Failed
3	L	H	H	Data rebuilding
4	H	L	L	Controller unit failure <sup>(*)</sup>
5	H	L	H	Reserved
6	H	H	L	<b>SATA Mirror Drive</b> startup processing
7	H	H	H	Initializing

H: TTL level output high.

L: TTL level output low.

**Note:**

<sup>(\*)</sup> The following condition will cause a Controller unit failure transmit status.

- If both drive units fail when the power is turned on.
- If both drive units are not properly connected when the power is turned on.
- If the correctly functioning drive unit is erroneously replaced when one of the drive units failed.

- The internal circuitry of status output signals are indicated as follows:

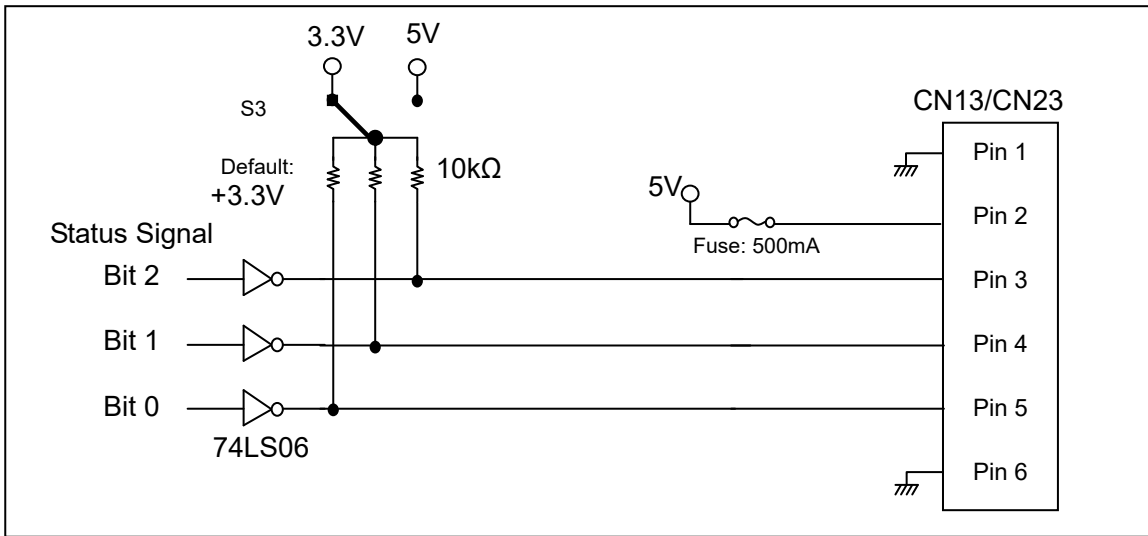

- Status Output Signal electrical specification

Voltage (Selectable Through S3)	Output High Voltage ( $V_{DC\ max}$ )	+3.3V (Default) / +5.0V (Option)
	Output Low Voltage ( $V_{DC\ max}$ )	+0.4V
Current	Output Sink (Low) Current ( $max$ )	20mA
	Output Source (High) Current ( $max$ )	0.25mA

- Connector specifications

	CN13	CN23
<b>SATA Mirror Drive</b> header	DF3Z-6P-2H (50)	DF11-6DP-2DS (24)
External Connector Crimp Socket – (recommended)	DF3-6S-2C	DF11-6DS-2C
External Connector Crimping Contact – (recommended)	DF3-248SCC	DF11-2428SCF/SC

Note: All components are from HIROSE Electric Co. Ltd.



### 5.2.2 External LED Connector

It is possible to drive external LED by CN14. Please refer to "2.1 Part Name's" for its location.

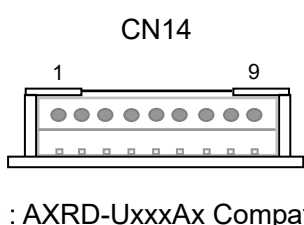
Pin No.	Status	Connector Pin Assignment
1	ACCESS LED Green	 <p style="text-align: center;">CN14</p> <p style="text-align: center;">Note : AXRD-UxxxAx Compatible</p>
2	GND	
3	ACCESS LED Orange	
4	DRIVE 1 Green	
5	GND	
6	DRIVE 1 Orange	
7	DRIVE 2 Green	
8	GND	
9	DRIVE 2 Orange	

● External LED Driver and recommended circuits.

The external LEDs indicate the same status as the LEDs on the front of the SATA Mirror Drive. External LEDs can be connected as shown below. The brightness can be adjusted by any resistor from 0 ohm to 150 ohm.

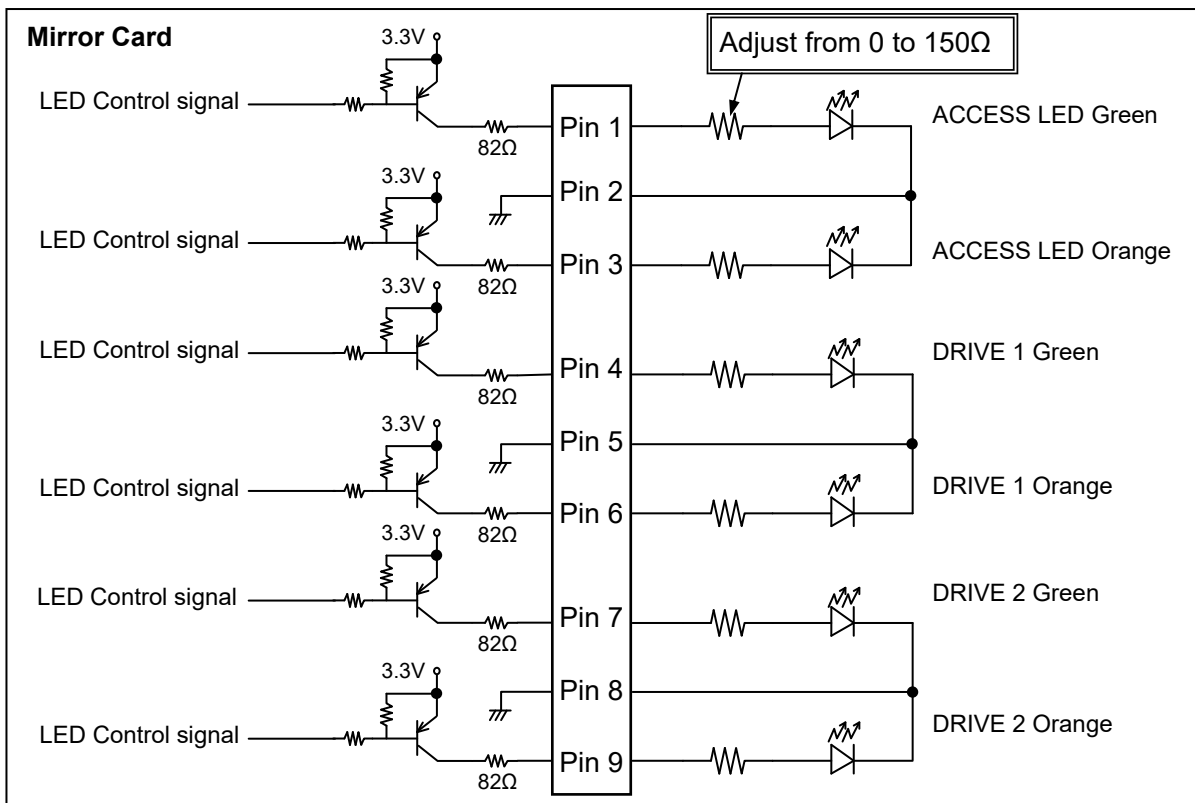

● CN14 Connector

	Part Name	Maker
<b>Mirror Drive Header</b>	DF3Z-9P-2H (50)	HIROSE Electric Co.,LTD
External Connector Crimp Socket – <i>(recommended)</i>	DF3-9S-2C	HIROSE Electric Co.,LTD
External Connector Crimping Contact – <i>(recommended)</i>	DF3-2428SCC	HIROSE Electric Co.,LTD

### 5.2.3 Buzzer Stop Connector

The buzzer can be stopped by a switch connected to the pin no. 3 and 5 of CN6. Please refer to "2.1Part Name's" for it's location.

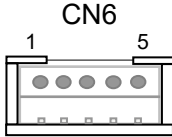
Pin No.	Functions	Connector Pin Position
1	Reserved ※	
2	Reserved ※	
3	5V	
4	GND	
5	Buzzer Stop	

※The Pins reserved must be open.

● Recommended circuits to stop buzzer

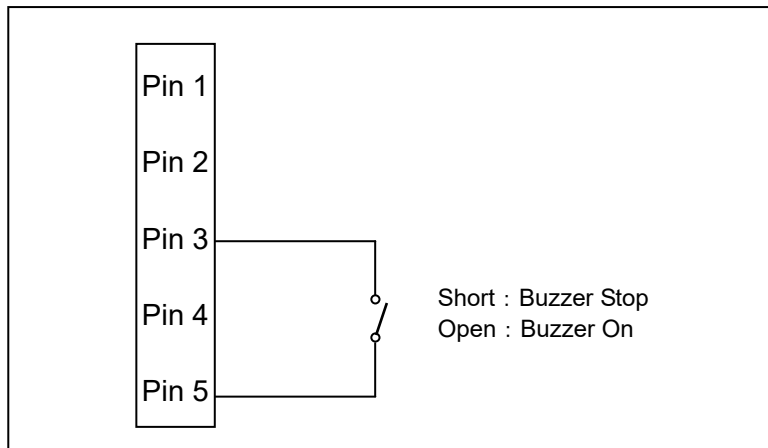

● CN6 Connector

	Part Name	Maker
<b>Mirror Drive Header</b>	DF3-5P-2DS (01)	HIROSE ELECTRIC Co.,LTD
External Connector Crimp Socket – <i>(recommended)</i>	DF3-5S-2C (01)	HIROSE ELECTRIC Co.,LTD
External Connector Crimping Contact – <i>(recommended)</i>	DF3-2428SCC	HIROSE ELECTRIC Co.,LTD

## 6. Trouble shooting

### 6.1 Trouble indication

If the **SATA Mirror Drive** fails, either the access indicator LED or the drive status indicator LED will flash Orange.

If the buzzer switch is enabled, the buzzer will emit a continuous beeping sound.

These status/failure indications must be considered to determine if removal and replacement of a hard disk unit is necessary.

Access indicator	Drive status indicator		<b>SATA Mirror Drive</b> status and measures.
	Drive unit 1	Drive unit 2	
---	Green	Orange flashing / Green	Rebuilding data from drive unit 1 to drive unit 2. (See Sections <a href="#">6.2.1-11</a> / <a href="#">6.2.2-9</a> / <a href="#">6.2.2-16</a> for more details)
---	Orange flashing / Green	Green	Rebuilding data from drive unit 2 to drive unit 1. (See Sections <a href="#">6.2.1-11</a> / <a href="#">6.2.2-9</a> / <a href="#">6.2.2-16</a> for more details)
---	Orange	---	Drive unit 1 failure. Replace the drive unit 1 with a new drive unit.
---	---	Orange	Drive unit 2 failure. Replace the drive unit 2 with a new drive unit.
Orange	---	---	Controller unit failure. Replace the controller unit with a new controller unit.
OFF	OFF	OFF	When the <b>SATA Mirror Drive</b> does not respond to the host, check the condition of the power supply. If problem persists, please contact your distributor.
Orange flashing	OFF	OFF	Check the condition of both drive units. If problem persists, please contact your distributor.
Orange flashing	Green	Green	Double-check to confirm that the desired drive unit was properly replaced. Temporarily return to the original setup and repeat the process.
Other LED indications not mentioned.			Contact your distributor.

--- : Normally off but will light up or flash when accessed.

If replacing the drive unit does not fix the problem, contact your distributor.

## 6.2 Replacing Drive Unit

A failed drive unit can be replaced while the **SATA Mirror Drive** is accessed. When the failed drive unit is replaced with a new drive unit, data rebuilding will begin automatically. During data rebuilding, the host computer can still access the **SATA Mirror Drive**.  
 Note: Make sure that the drive status indicator (LED) lights orange before replacing a failed unit.

	<p><b>Important</b></p>	<p>Before replacing the failed drive unit, be sure to prepare the replacement drive unit designated by STR-V as described in "<a href="#">Appendix-D Replacement Parts</a>". Do not replace with HDDs other than the designated model, even if the capacity, manufacturer, or model numbers on the label are the same. Using an unauthorized HDD may result in malfunction or damage. The warranty does not cover any damage encountered due to replacement with a non-specified HDD. Furthermore, STR-V is not held liable for any consequence resulting from the use of an undesigned HDD.</p>
---	-------------------------	--

	<p><b>Important</b></p>	<p>If the drive status indicator lights orange, immediately replace the specified drive unit with a new drive unit. Leaving the <b>SATA Mirror Drive</b> with a single operational drive unit for an extended period will result in data loss if the other drive unit fails.</p>
---	-------------------------	--

	<p><b>Caution</b></p>	<p>Before handling the drive unit when replacing a failed drive, touch a metal object first, such as the metal enclosure of the host computer, to discharge static electricity from your body.</p>
---	-----------------------	--

### 6.2.1 Replacement of 1 Drive Unit

- Drive Unit Replacement Procedure.

1. Prepare a new drive unit as specified in "[Appendix-D Replacement Parts](#)."
2. Confirm correct identification of the failed drive unit through the drive status indicator or buzzer.
3. If the failed drive unit can not be removed during power ON, turn off the power supply of the host computer and remove the **SATA Mirror Drive**.
4. Slide the front lever to the left and release the lever.
5. Pull the failed drive unit's lever, and then pull out the drive unit.
6. Push the replacement drive firmly into the unit with both hands.
7. Slide to the front lever to the right and close the lever.
8. Confirm that the front lever is fixed.
9. If the **SATA Mirror Drive** was removed, set it back into the host computer, turn on the power and confirm that the host computer recognize the **SATA Mirror Drive**.

- Several seconds after replacing the drive unit, data rebuilding will start. The drive status indicator of the replaced drive unit will flash orange (@ 1 second interval).

	<b>Important</b>	Do not remove the drive unit while data rebuilding is underway.
---	------------------	---

- During data rebuilding, the drive status indicator of the replacement drive will flash orange, and the drive status indicator of the fully functional drive unit will light green. The access indicator will not light.
- When data rebuilding is complete, the drive status indicator will go out.

	<b>Important</b>	<p>If you have mistakenly replaced the correctly functioning drive unit, the drive status indicator of both drive units will light green. Then the access indicator will flash orange. The host computer will be unable to operate the <b>SATA Mirror Drive</b>.</p> <p>In this case, turn off the host computer. Replace the failed drive unit with the new drive unit, and return the fully functional drive unit. Data rebuilding will immediately start after turning on the host computer.</p>
---	------------------	---

### 6.2.2 Replacement of Both Drive Units

When both drive units seem to have failed, replace the units according to the following procedure.

	<b>Important</b>	<p>This is an emergency recovery procedure; data corruption may or may have already occurred.</p> <p>To avoid further data loss, back up your data in a suitable medium, such as tape or MO drive.</p> <p>Please use an STR-V designated HDD as drive replacement. Refer to "Appendix-D Replacement Parts" for more details.</p>
---	------------------	--

- Prepare the two new drive units as specified in "[Appendix-D Replacement Parts](#)."
- Turn off the power supply of the host computer.
- The drive unit to be replaced first should be the one that failed first. Slide to the left the grooved mark on the front lever and open the lever.
- Hold the lever of the drive unit that failed first and then pull it out.
- Turn on the power supply of the host computer.
- Confirm that the host computer recognizes the **SATA Mirror Drive**.
- After confirming that the host computer recognizes the **SATA Mirror Drive**, insert the replacement drive. Push firmly the replacement drive right into the unit with both hands then with the use of the grooved marking, carefully slide the lever to the right.
- Several seconds after replacing the drive unit, data rebuilding will start. The drive status indicator of the replacement drive unit will flash orange (@1 second interval).

	<b>Important</b>	Do not remove the drive unit while data rebuilding is underway.
---	------------------	---

9. During data rebuilding, the drive status indicator of the replacement drive will flash orange, while the drive status indicator of the other drive unit will light green. The access indicator will not light.
10. When data rebuilding is complete, the drive status indicator will go out.  
After confirming that the drive status indicator has gone out, turn off the power supply of the host computer.
11. Slide to the left the grooved mark of the lever of the un-replaced drive unit and open the lever. Hold the lever of the driver unit, then pull it out.
12. Push firmly the replacement drive right into the unit with both hands then with the use of the grooved marking, carefully slide the lever to the right.
13. Confirm that the front lever is locked.
14. Turn on the power supply of the host computer.
15. Several seconds after replacing the drive unit, data rebuilding will start. The drive status indicator of the replacement drive unit will flash orange (@1 second interval).

	<b>Important</b>	Do not remove the drive unit while data rebuilding is underway.
---	------------------	---

16. During data rebuilding, the drive status indicator of the replacement drive will flash orange, while the drive status indicator of the fully functional drive unit will light green. The access indicator will not light.
17. When data rebuilding is complete, the drive status indicator will go out.

## 6.3 Controller Unit Replacement

If the access indicator or the drive status indicator lights orange even after drive replacement, the controller may have a problem. In this case, replace the controller unit.

When replacing the controller unit, data can be kept safe by following the correct replacement procedure.

Note that the replacement procedure will differ depending on the drive units' status.

<1> If both drive units are functioning normally:

Switch over both drive units to a new controller unit.

Ensure that each drive unit is inserted into exactly the same drive bays as before.

<2> If one drive unit has failed:

When it has been confirmed that one drive unit has failed, ensure that only the correctly functioning drive unit is inserted into the same bay of the new controller.

	Caution	When replacing controller units, make sure to turn off the power of the host computer, and the AC power cable is removed from the socket.
		When replacing drive units, ensure that you touch the chassis or any other grounded parts, to discharge static electricity from your body.
		Do not subject the drive units or the controller to vibration or shock. It may result in malfunction or disk failure.

### 6.3.1 When both drive units are functioning normally

- Controller Unit Replacement Procedure.

1. Prepare a new controller unit as specified in "[Appendix-D Replacement Parts](#)."
2. Turn off the power supply of the host computer.
3. Disconnect the SATA Signal cable and the power cable. Then remove the **SATA Mirror Drive** from the host computer.
4. Slide to the left the grooved mark on the front lever and open the lever.
5. Release both drive units' lever one after the other and then pull it out.
6. Insert the drive units into the new controller unit. Make sure drive unit numbers 1 and 2 are kept as they were before replacement. One after the other, push firmly the drives right into the unit with both hands then with the use of the grooved marking, carefully slide the lever to the right.
7. Confirm that both front levers are fixed.
8. Re-install the **SATA Mirror Drive** back into the host computer then re-connect the SATA Signal cable and finally, the power cable.
9. Turn on the power supply of the host computer.

### 6.3.2 When one drive unit has failed:

- Controller Unit Replacement Procedure.

1. Prepare a new drive unit and a new controller unit as specified in "[Appendix-D Replacement Parts](#)."
2. Confirm which drive unit has failed through the drive status indicator or buzzer.
3. Turn off the power supply of the host computer.
4. Disconnect the SATA Signal cable and the power cable. Then remove the **SATA Mirror Drive** from the host computer.
5. Slide to the left the grooved mark on the front lever of the good drive and open the lever.
6. Pull out the good drive unit first.

7. Insert the good drive unit into the new controller unit.  
Please keep the location of the drive unit (number 1 or 2) as it was before.  
Push firmly the drive right into the unit with both hands then with the use of the grooved marking, carefully slide the lever to the right.
8. Confirm that the front lever is fixed.
9. Install the **SATA Mirror Drive** into the host computer then re-connect the SATA Signal cable and finally, the power cable.
10. Turn on the power supply of the host computer.
11. Confirm that the host computer recognizes the **SATA Mirror Drive**.
12. Insert the new drive unit into the other empty slot.  
Push firmly the replacement drive right into the unit with both hands then with the use of the grooved marking, carefully slide the lever to the right.
13. Confirm that the front levers are fixed.
14. Several seconds after replacing the drive unit, data rebuilding will start. The drive status indicator of the replacement drive unit will flash orange (@1 second interval).

	<b>Important</b> Do not remove the drive unit while data rebuilding is underway.
--	--

15. During data rebuilding, the drive status indicator of the replaced drive will flash orange, while the drive status indicator of the fully functional drive unit will light green. The access indicator will not light.
16. When data rebuilding is complete, the drive status indicator will go out.

## 6.4 Other problems

If the problem persists even after you have replaced the drive unit or the controller unit, please contact your distributor.

In addition, if you also happen to encounter other types of problems not mentioned in this manual, please contact your distributor immediately.



# Appendix-A Specifications

## A.1 Product Specifications

Model Name		SVRE-U080SA	SVRE-U320SA1
RAID Level		1	
Number of HDDs		2	
Storage Capacity		80GB	320GB
Cache Size		1MB	
Number of LBAs		156,297,344	625,138,304
Number of Cylinders		16,383	
Number of Heads		16	
Sectors		63	
Host interface		SATA	
Data transfer rate (max)		3Gbps	
Dimensions (W x L x H)	SATA Mirror Drive	101.6 mm x 144.5 mm x 25.4 mm	
	5-inch Bay Mirror Drive Installation Attachment	146.0 mm x 144.5 mm x 43.0 mm	
Weight	SATA Mirror Drive	520 g	
	5-inch Bay SATA Drive Installation Attachment	720 g	
Voltage (VCC)		4.85 V <sub>DC</sub> ~ 5.25V <sub>DC</sub>	
Power supply ripple (max) (*1)		100mV p-p (0~20MHz)	
Power startup time (*2)		5~100ms	
Operating Environments (*3)	Temperature	5 to 45 °C (Operating) <sup>(*4)</sup> -40 to 60 °C (Non-operating)	
	Humidity	8 to 90% (Operating) 5 to 95% (Non-operating)	
	Max. Bulb Temp.	29°C (Operating) 40°C (Non-operating)	
Current Requirement	Startup (max)	2.1A	
	Idle (Typ)	1.4A	
	Read/Write (Typ)	1.6A	

**Note:**

<sup>(\*1)</sup>: Including startup time.

<sup>(\*2)</sup>: Time until V<sub>CC</sub> reaches 4.85 V<sub>DC</sub>.

<sup>(\*3)</sup>: With no condensation.

<sup>(\*4)</sup>: When mounting to the host computer, provide sufficient cooling to keep the surface temperature of the drive unit below 60°C.

## Appendix-B Accessories

---

The **SATA Mirror Drive** (SVRE-U Series) is shipped with following accessories.

- Mounting screws. (4pcs.)

## Appendix-C Factory Default Setting

The **SATA Mirror Drive's** factory default settings are as follows:

- DIP Switch Settings

		Default Setting	
			
Function / Mode	SW No.	DIP SW SETTING	
Normal Mode	Mirror Mode	S1	OFF
		S2	OFF
		S3	OFF
Reserved	---	S4	OFF
Write Cache (Write Back)	Enabled	S5	OFF
Revival Reconstruction.	Enabled	S6	OFF
Buzzer	Enabled	S7	OFF
Reserved	---	S8	OFF

- Status Output Signal Electrical : **3.3V**

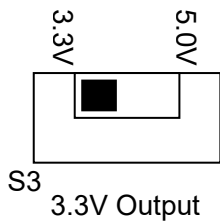

## Appendix-D Replacement Parts

---

The following are supplied as user-replaceable parts.

Model Name	Part Name	Part Number
SVRE-U080SA	80GB drive unit	A204129
		A204210
		A204372
	80GB Controller unit	A204111
SVRE-U320SA	320GB drive unit	A204130
		A204211
		A204373
	320GB Controller unit	A204265

# Information

---

For more information about this product, please contact your distributor.

Distributor's information

- Product Records

Model Name	SVRE-U
Revision	YB-
Serial Number	

- Manufacturer



This product is manufactured by  
Storage Vision Co., Ltd. Japan.

<http://www.str-v.com>